

**!ATTENTION: READ BEFORE ASSEMBLING/OPERATING!**

**ASSEMBLY & PACKING INSTRUCTIONS FOR THE MULTICHAIR BIG WHEEL SERIES**



**multichair 4020**



**multichair 4024**



**multichair 4020Rx**



**multichair 4220**



**multichair 4224**



**multichair 4220Rx**

**!ATTENTION: READ BEFORE ASSEMBLING/OPERATING!**

# ASSEMBLY INSTRUCTIONS

## !ATTENTION: PLEASE READ!

Please see LIMITED WARRANTY of these instructions. If the warranty is not acceptable, contact Nuprodx, Inc. for information about returning the chair for a refund (Restocking fees and shipping charges will be applied). This chair is designed and intended for indoor shower and bathroom use. It is not designed for outdoor use and will void the warranty if used in this fashion. If thresholds, shower curbs or barriers are encountered that exceed ½" in height, the area in question should be brought within the code for disabled accessibility.



Figure 1 multiCHAIR 4020 shown

**A** The multiCHAIR 4020 is shown in Figure 1 (other big wheel chairs are similar).

**B** Unpack all parts from the shipping carton. Remove all tape and/or packing from the chair. Keep shipping materials for future use. Note the location of padding materials and sheet plastic which protects parts of your chair.

**C** Position the seat frame upside down and install the four legs. Note that the top of each leg has a machined portion approximately one inch wide. The back two legs have a 1" offset piece attached to the ends. Install the back two legs so that the offset points out at a 90-degree angle and note that the small pin must mate with the holes in the frame (Refer to Figure 3).

### SAFETY PRECAUTION!

If the small pins are not mated with the seat frame correctly there is an extreme risk of the legs dislodging completely from the chair. This could cause serious injury or even death!

**D** The top end of each leg should fit easily into the socket of the frame. Make sure that the legs slide "home" into the sockets. Use the included ¼" Allen wrench to tighten the bolts located at the corners of the frame. For ease of future leg height adjustment, position each leg in the socket so that the adjustment holes face outward (Refer to Figure 2).

### SAFETY PRECAUTION!

If any of the legs are not fitted correctly into the socket of the seat frame or are not securely tightened there is an extreme risk of the legs dislodging completely from the chair. This could cause serious injury or even death!

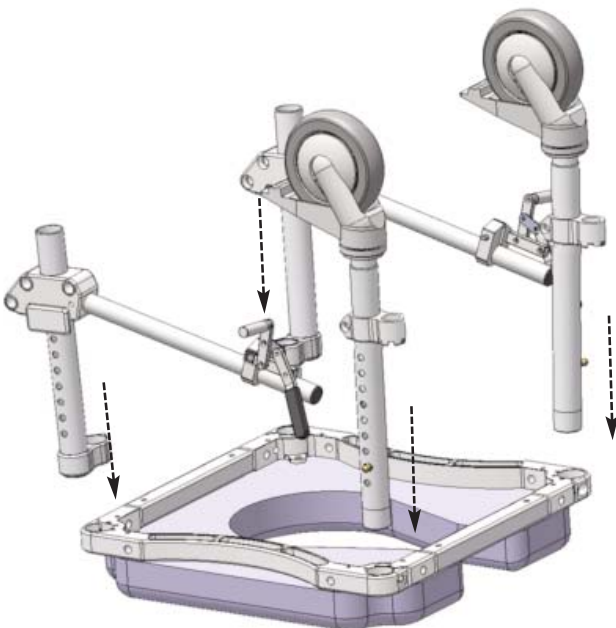

Figure 2

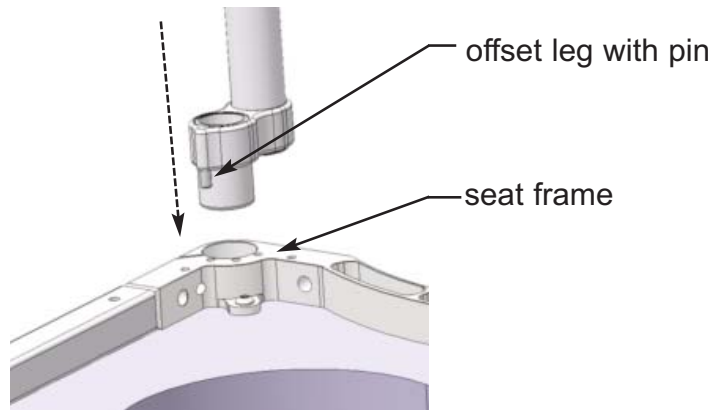

Figure 3



Figure 4

**E** Turn the chair right side up and install the backrest assembly. Slide the two backposts into the back of the seat frame and tighten the two socket head cap screws using the ¼" Allen wrench also tighten the four button head capscrews that attach the back cushion to the back posts (Refer to Figures 4 & 5). For details on the 20" frames (Refer to Figure 6).

**SAFETY PRECAUTION!**

Both backrest posts must be completely engaged with the seat frame and securely tightened. If they are not fitted correctly, there is a risk of the posts dislodging from the seat frame. This could cause serious injury or even death!

**F** Install the swing-away footrests by sliding the gooseneck tubing/foot paddle into the clamp that is attached to the front legs (Refer to Figure 7).

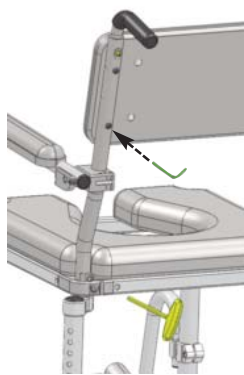

Figure 5

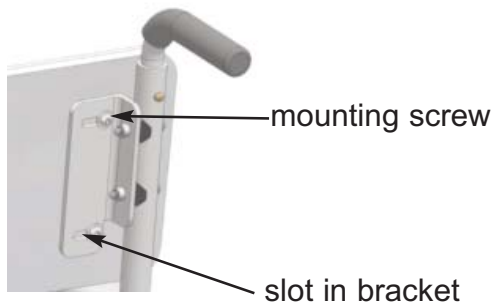

Figure 6

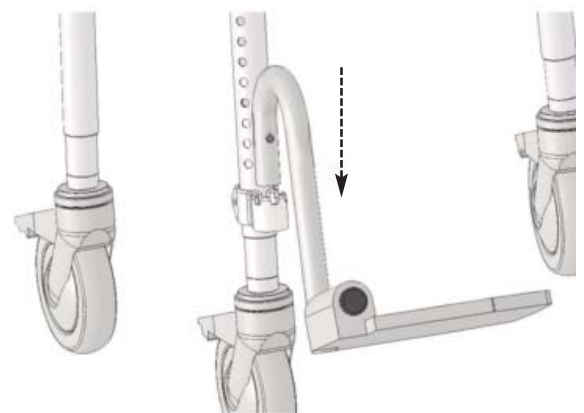

Figure 7

**ADDITIONAL ASSEMBLY INSTRUCTIONS**

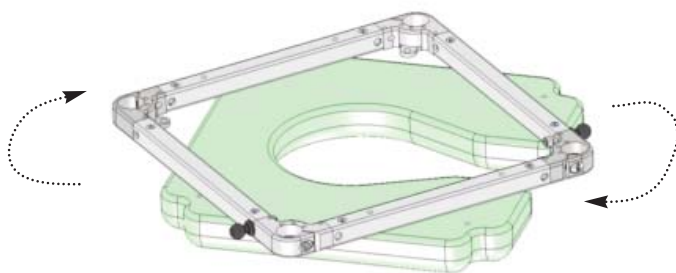

Figure 8

**A Seat Cushion Orientation:** The standard seat cushion orientation is with the commode opening in the front of the multiCHAIR. If desired, the commode opening can also be orientated left/right/rear. This can be accomplished by unscrewing the four button head cap screws that attach the cushion to the frame, orientating the commode opening to the desired location and then re-attaching the cushion to the frame with the four screws using the 5/32" Allen wrench (Refer to Figure 8).

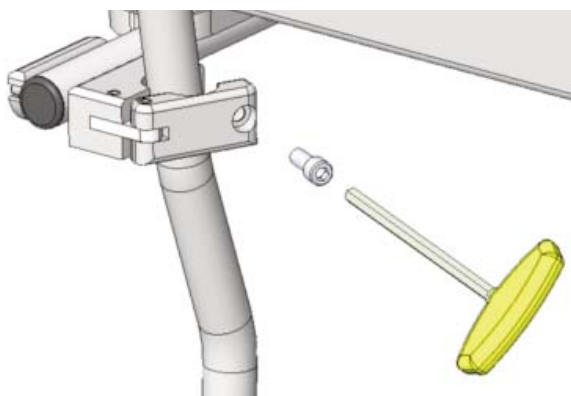

Figure 9

**B Cantilever Arms:** If desired, the cantilever arms can be removed from the backrest assembly for storage during traveling. This can be accomplished by unscrewing the socket head cap screws that attach the arms to the backrest posts using the 5/32" Allen wrench. Then remove the arm assemblies from the posts and re-insert the socket head cap screws into the arm assemblies, so they are not lost. To re-install the cantilever arms, simply follow the steps above in reverse (Refer to Figure 9).

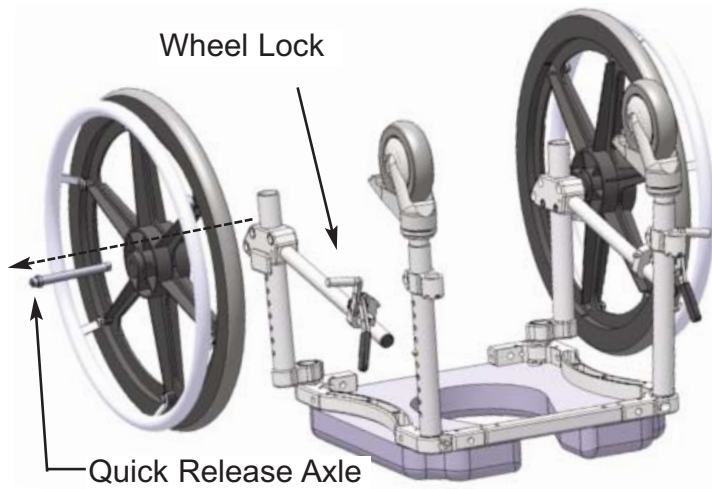

Figure 10

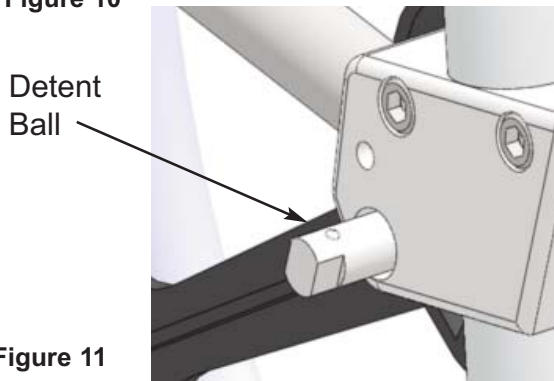

Figure 11



multiCHAIR 4020rx

Figure 12



Figure 13

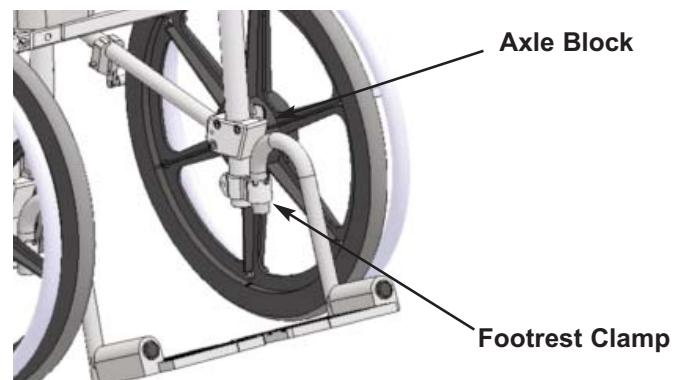

Figure 14

**C Removal of 20", 22" or 24" Wheels:** If desired (for storage/cleaning purposes) the big wheels can be removed from the leg assemblies by completing the following steps (Refer to Figure 10).

- 1) Make sure the wheel locks are in the unlocked position.
- 2) Press down on the button of the quick release axle located in the center of the wheel.
- 3) With the quick release axle button depressed, pull the entire wheel assembly (handrim/wheel/quick release axle) outward.
- 4) To reinstall the wheels, simply reverse the process above.

**SAFETY PRECAUTION!**

When reinstalling the quick release axle into the axle block, ensure that the detent balls are engaged by trying to pull out the axle (Refer to Figure 11). There should be a slight amount of back and forth movement. If the quick release axle is not reinstalled into the axle block correctly the whole wheel assembly could dislodge during usage. This could cause serious injury or even death!

**D Converting the multiCHAIR 4020 to a multiCHAIR 4020rx** (This operation is recommended for chairs with 20" size wheels only): If desired, the 20" wheels can be switched with the front caster wheels and assembled to be in the front of the chair (Refer to Figure 12). Note: Longer footrest clamps can be purchased from Nuprodx as an optional item.

- 1) Remove the back assembly from the chair: Reverse the process shown on Page 2 [Assembly Instructions] Step E (Refer to Figures 4 & 5).
- 2) Remove the four legs from the seat frame: Reverse the process shown on Page 1 [Assembly Instructions] Step C (Refer to Figure 2).
- 3) Remove the two 5" casters and the footrest clamps from the front two 11-Hole outer legs (Refer to Figure 13).
- 4) Remove the two 20" wheels from the axle blocks as shown in Step C above.
- 5) Remove the two axle blocks from the 10-Hole offset outer legs and re-install onto the two 11-Hole outer legs (Refer to Figure 21 on Page 5).
- 6) Re-install the two footrest clamps onto the 11-Hole outer legs and locate them underneath the axle blocks (Refer to Figure 14).

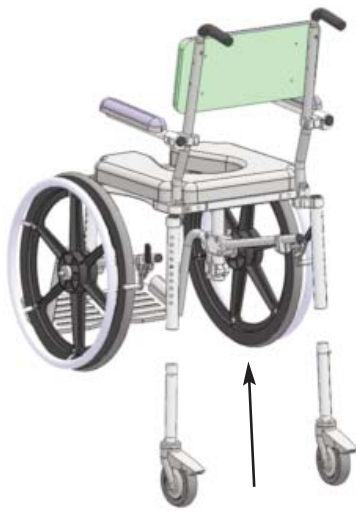

Figure 15

- 7) Re-install the two 5" casters into the 10-Hole offset outer legs (Refer to Figure 15).
- 8) Re-assemble the entire chair by completing Steps C, D, E & F on Pages 1 & 2 [Assembly Instructions]

## OPERATING INSTRUCTIONS

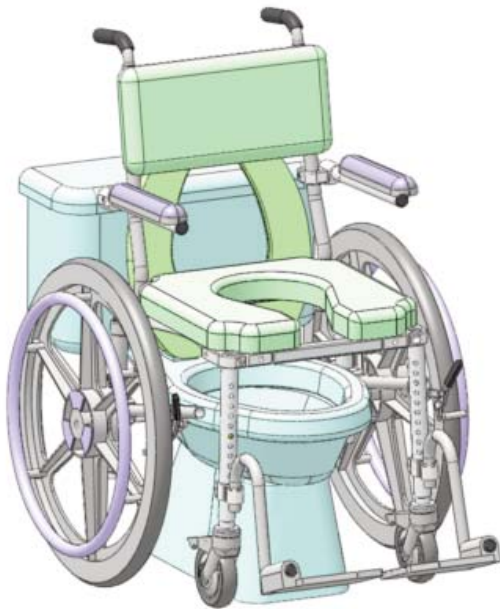

Figure 16

**A** Ensure all fasteners (bolts/washers) are securely tightened and all chair parts have been assembled correctly (Refer back to Assembly Instructions if needed. Contact Nuprodx, Inc. if unsure of anything).

**B Commode Chair:** Position the multiCHAIR over the toilet, so that the center of the commode opening is directly above the center of the toilet bowl. Adjust the height of the multiCHAIR accordingly by setting the position of the brass buttons on the two inner legs to the various adjustment holes on the outer legs (Note: For height adjustment of the big wheels, refer to Step F on Page 4). Then lock the caster wheels in place. Note: Make height adjustments to the multiCHAIR before the user has transferred onto it (Refer to Figure 16).

### SAFETY PRECAUTION!

Ensure that the height of each inner leg is set to make the multiCHAIR level. If this is not properly done, the multiCHAIR could tip to one side causing the user to fall. This could result in serious injury or even death!

**C Shower Chair:** Position the multiCHAIR inside the shower. Adjust the height of the multiCHAIR accordingly by setting the position of the brass buttons on the four inner legs to the various adjustment holes on the outer legs. Note: Make height adjustments to the multiCHAIR before the user has transferred onto it.

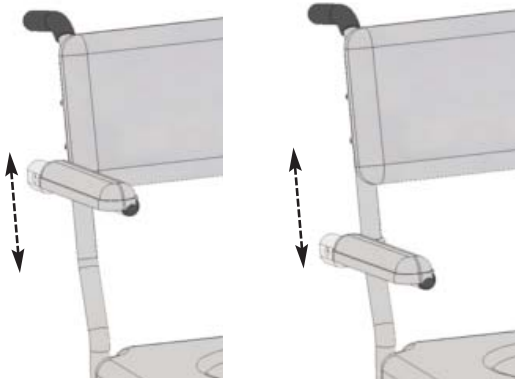

Figure 17

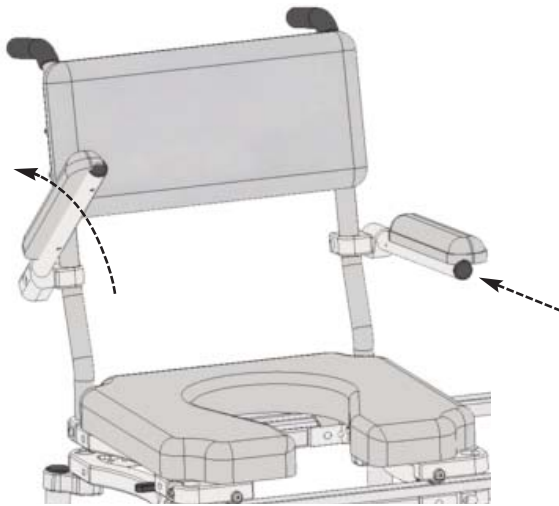

Figure 18

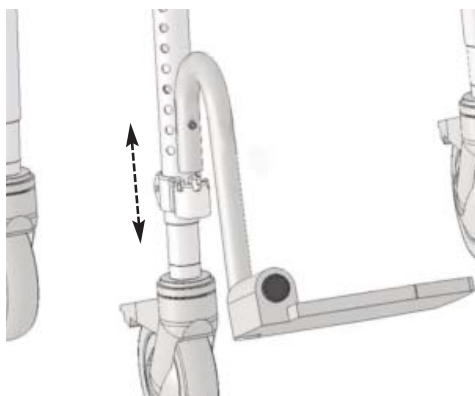

Figure 19

**D Cantilever Arms:** The cantilever arms can be adjusted to the desired height by completing the following steps: Loosen the socket head cap screws on the arm clamps, raise/lower the arms accordingly, then re-tighten the socket head cap screws (Refer to Figure 17). For safety purposes, the cantilever arms lock in the down position. To switch the arms to the up position, simply push the arms toward the back of the chair (releasing the locking mechanism) and lift up (Refer to Figure 18).

**E Footrest Assemblies:** Footrest clamps are installed on the front legs at the factory. Slide the footrest into the clamp. Loosen the pinch bolt on the footrest clamp and slide up/down as required by the user's leg length (Refer to Figure 19).

### SAFETY PRECAUTION!

The swing-away footrests should be installed into the footrest clamps after the user has been transferred into the chair. Putting an extreme amount of weight on the swing-away footrests or using them as an assistive device when transferring can cause the entire chair to tip forward, resulting in serious injury or even death!

**F Big Wheel Height Adjustment:** To adjust the height of the big wheel assemblies proceed with the following steps:

- 1) Remove the big wheels from the axle blocks as shown in Step C on Page 3 of the Additional Operating Instructions
- 2) Loosen the bolts holding the indexing plates to the axle blocks using the included T-Handle allen wrench and move the entire assembly up or down as required to match the height of the two front caster wheels (Refer to Figure 20).
- 3) Once you have the axle block assemblies in place, make sure that the pins located on the indexing plates are fully seated in the outer leg holes (Refer to Figure 20).
- 4) Tighten the bolts holding the indexing plates to the axle blocks using the included T-Handle allen wrench.
- 5) Reinstall the big wheels into the axle blocks

### SAFETY PRECAUTION!

If the axle blocks are not properly installed onto the outer leg holes, this could cause the big wheel assemblies to dislodge from the chair, resulting in serious injury or even death!

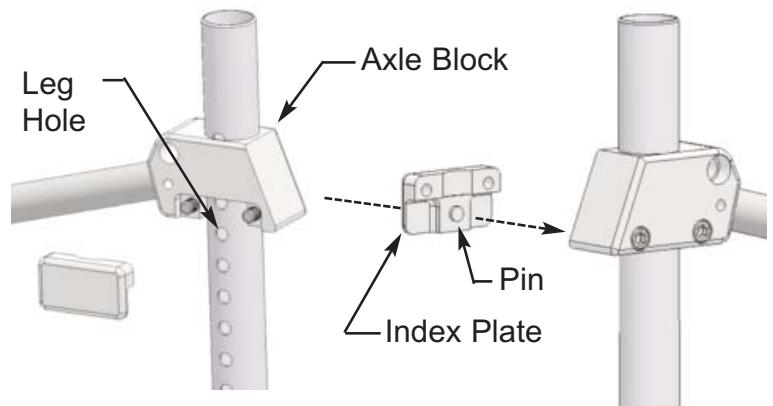

Figure 20

# ADDITIONAL SAFETY PRECAUTIONS

## !ATTENTION: PLEASE READ!

**WARNING!** Failure to account for the aforementioned and the following safety precautions can result in serious injury to the user or even death!

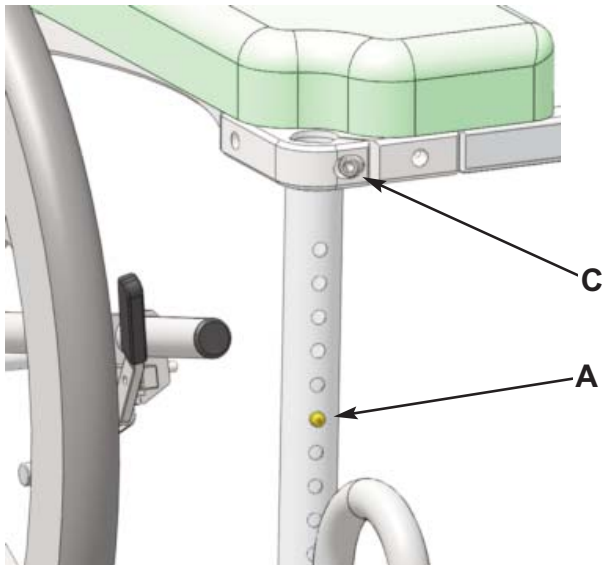

Figure 21

**A Leg Height Adjustment:** When making height adjustments to any of the legs, make sure that the brass buttons are fully engaged into the outer legs. If pushed too hard the button could become stuck inside the inner leg (Contact NuprodX, Inc. if this occurs). Leg height adjustment should only be made before transferring the user into the chair (Refer to Figure 21).

**B Caster Wheels:** Before transferring into and out of the chair, both the two front caster wheels and the two rear wheels must be securely planted onto the floor and switched to the locked position. Failure to do so could cause the chair to become unstable (Refer to Figures 22 & 23).

**C Fasteners:** Over time the screws and washers on the chair may become loose. It is very important that these are checked and securely tightened before each use. Failure to do so could cause a part to dislodge from the chair (Refer to Figure 21).

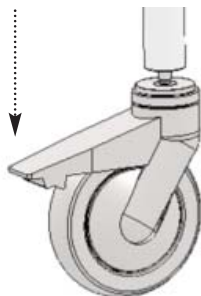

Figure 22

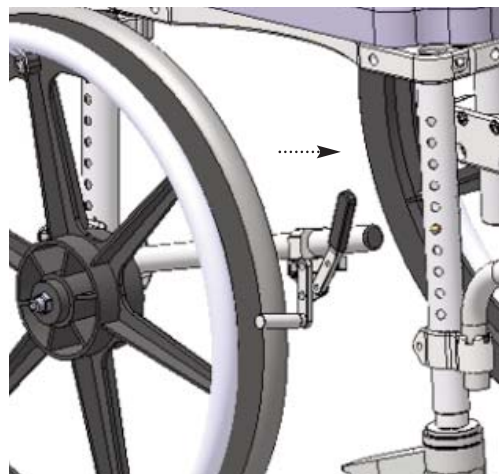

Figure 23

# LIMITED WARRANTY

**A WARRANTY ACTIVATION** Please read this warranty before operating or using your multiCHAIR. To activate the warranty on your multiCHAIR register it online by phone. By operating or using the chair, you agree to the terms of this warranty.

**B WARRANTY:** Nuprodx, Inc. warrants this product against defects in material and workmanship as follows: There is a *10-Day conditional money-back warranty*. During this time period, the customer is permitted to try out the multiCHAIR, fully-clothed, keeping the chair in “like new” condition (NOTE: “Like new” condition, in terms of the multiCHAIR, is defined by Nuprodx, Inc. as no visible wear/usage/water marks for the multiCHAIR to be accepted and refunds issued when returned to Nuprodx, Inc.). If the customer decides that the multiCHAIR will not work for them, before the 10-Day period has passed and with the authorization of Nuprodx, the chair can be returned for a full refund minus a *10% restocking charge* (NOTE: The customer is responsible for both in-bound and out-bound freight). After the initial 10-Day period has passed, there is a *two-year limited warranty* for all parts of the chair, with the exception of the seat and back cushions. The seat and back cushions carry a *one year limited warranty*. The warranty does not cover normal “wear and tear” from everyday use of the product and custom parts/custom cushions are also excluded from the warranty and cannot be returned for a refund under any circumstances. Please see section E WARRANTY LIMITATION AND EXCLUSIONS for more info on warranty exclusions.

**C** The warranty period begins on the date you receive the chair. For warranty service, please contact Nuprodx, Inc. no later than one month following the applicable warranty term. The chair will be repaired or replaced at the discretion of Nuprodx, Inc. with no charges to you for parts and labor, provided you have proof of purchase and of purchase date.

**D DISCLAIMER:** Except for the above warranty, and the acknowledgement by Nuprodx, Inc. that the chair, as manufactured by it, is fit for the general purpose for which most persons acquire a chair of its kind, Nuprodx, Inc. provides that you accept the chair as is, without warranties, either express or implied. Nuprodx, Inc. makes no warranty of fitness for your particular purpose and no warranty of merchantability beyond that already stated. No warranties extend beyond the duration of the express warranty stated above.

**E WARRANTY LIMITATIONS AND EXCLUSIONS:** The only obligation of Nuprodx, Inc. is to provide the purchaser with free repair and replacement as described above. This exclusive warranty remedy will not have failed as long as Nuprodx, Inc. is willing and able to repair or replace as described, but if this remedy should be held to have failed, the only remaining warranty obligation of Nuprodx, Inc. shall be to refund the acts beyond the control of Nuprodx, Inc. The warranty does not cover normal “wear and tear” from everyday use of the product. Custom parts/custom cushions are not covered under the warranty.

**F** This warranty gives you specific legal rights, and you may have other rights that may vary from state to state.

**G** This warranty does not apply to problems arising from normal wear, improper operation, improper maintenance, improper storage or similar disclaimer of implied warranties, and some do not allow limitations on how long an implied warranty may last. Some do not allow exclusion or limitation of incidental or consequential damages. So the above limitations or exclusions may not apply to you.

**H RETURN INSTRUCTIONS** In the event that you need to return the Nuprodx multiCHAIR, please follow the instructions below:

- 1) Review the information contained in your warranty to see if this applies to you
- 2) Obtain a Return Authorization # from Nuprodx, Inc
- 3) Re-package the entire chair and its contents in the original packaging and ship to the following address:





# PACKING INSTRUCTIONS

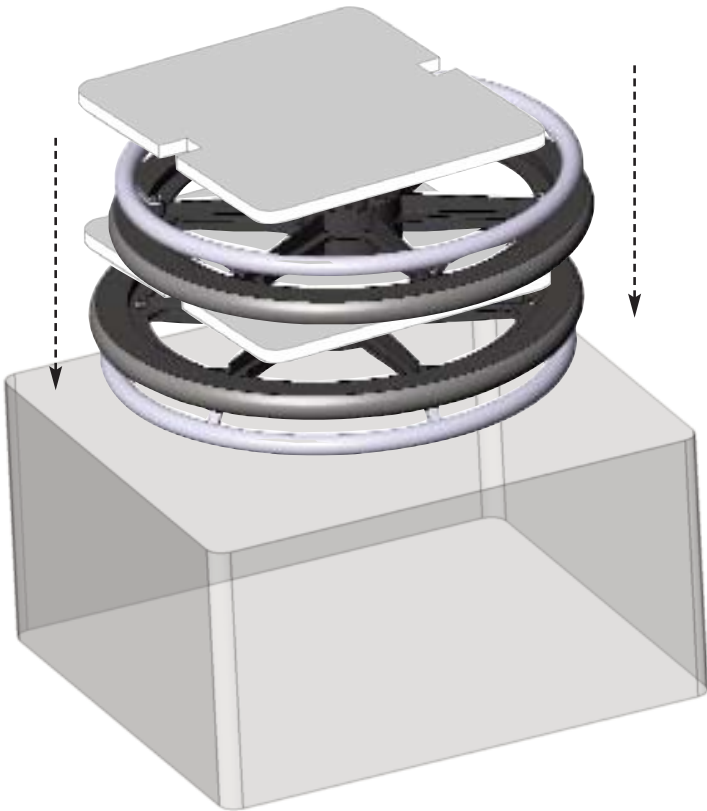

**Figure A** - Place one wheel (handrim side down) in the carrying case. Place a piece of foam followed by the other wheel (handrim side up) and a second piece of foam.

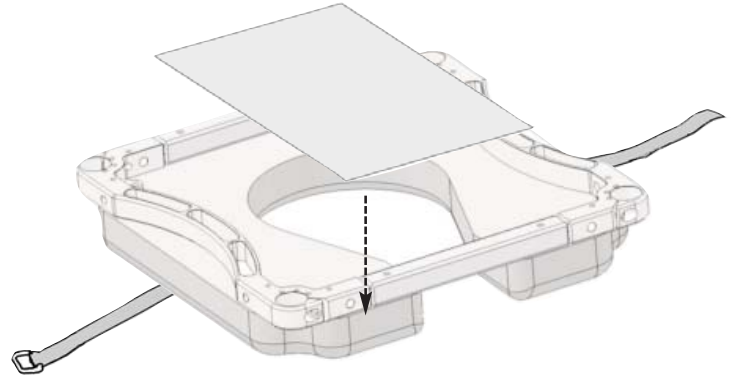

**Figure B** - Drape the black strap across the foam covered wheels already in the carrying case (case not shown for clarity). Center the inverted frame & plastic panel inside the case.

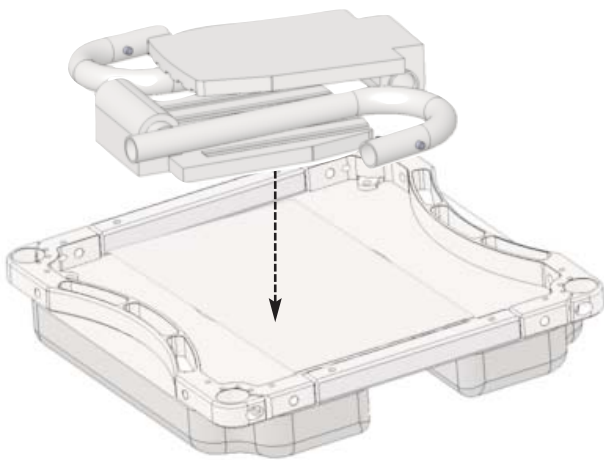

**Figure C** - Center the folded footrests (one inverted) on the plastic panel and position as shown.

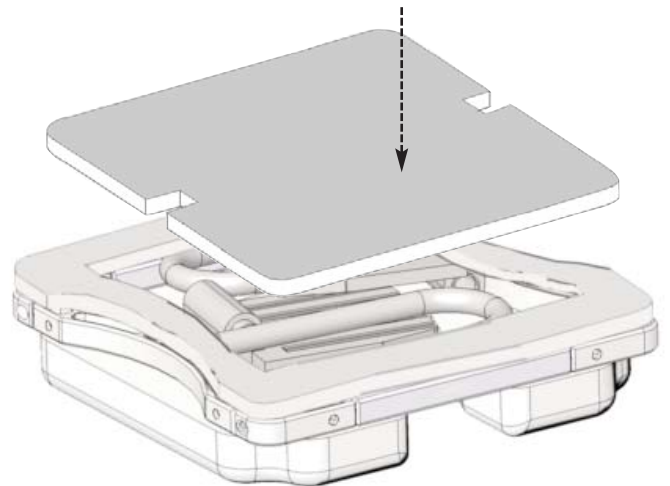

**Figure D** - Center the foam square on top of the frame.

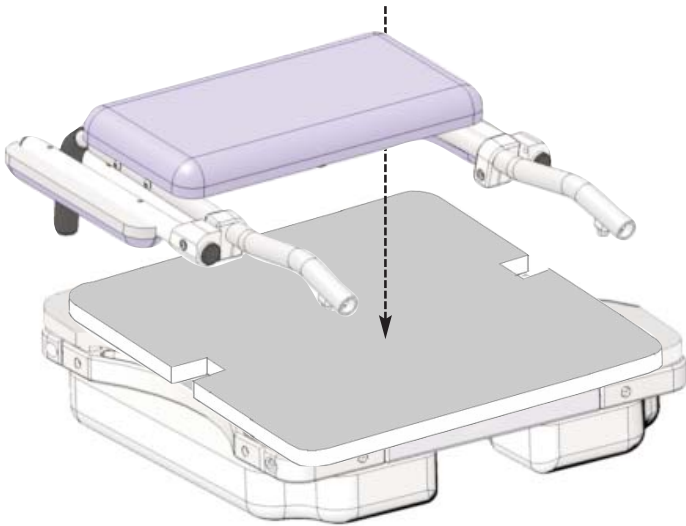

**Figure E** - Center the backrest assembly on top of the foam, inverted frame with footrests, etc (wheels not shown for clarity).



**Figure F** - Tighten & buckle the black strap around the inverted frame & backrest assembly.

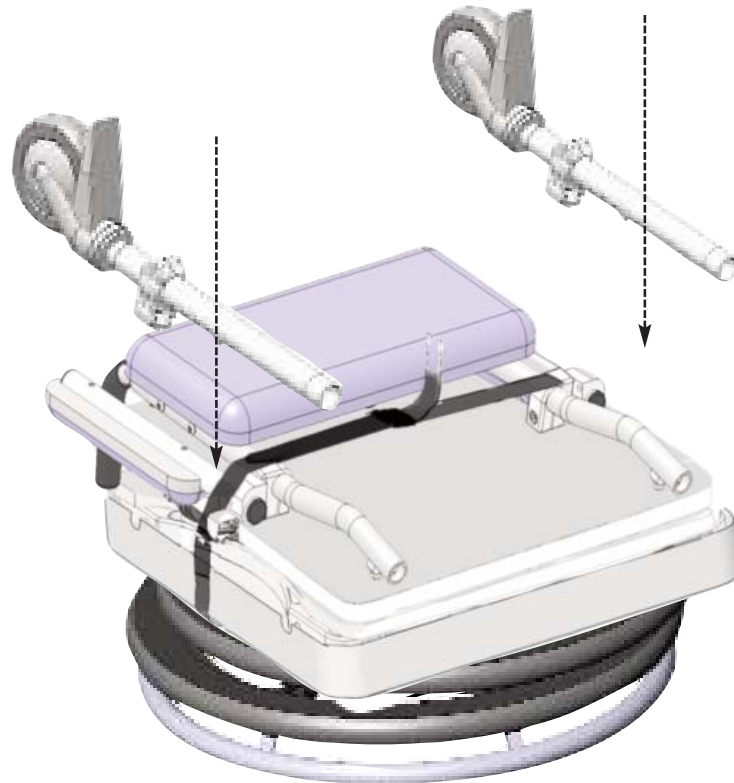

**Figure G** - Place one front caster leg, above the wheels, on each side of the inverted frame & backrest assembly.

