



PRODUCT DESCRIPTION
FULL BACK SLING

PAGE 1/1

COMPANY ADDRESS
 JOERNS HEALTHCARE (POLY)
 HIGH STREET
 WOLLASTON
 WEST MIDLANDS DY8 4PS

TELEPHONE/FAX
 TEL +44 (0) 1384 446622
 FAX +44 (0) 1384 446601

EMAIL /WEB
 EMAIL:ltcorders@joerns.co.uk
 WEB:www.joerns.co.uk

PLEASE COMPLETE THE FOLLOWING SECTIONS AND RETURN TO JOERNS HEALTHCARE LIMITED BY FAX

DEALER NAME
DELIVERY ADDRESS
TEL No. **FAX No.**

ACCOUNT No.
DATE D D M M Y Y Y Y
REQUEST BY
QUANTITY

DIAGRAM OF SLING LAID FLAT AS VIEWED FROM ABOVE

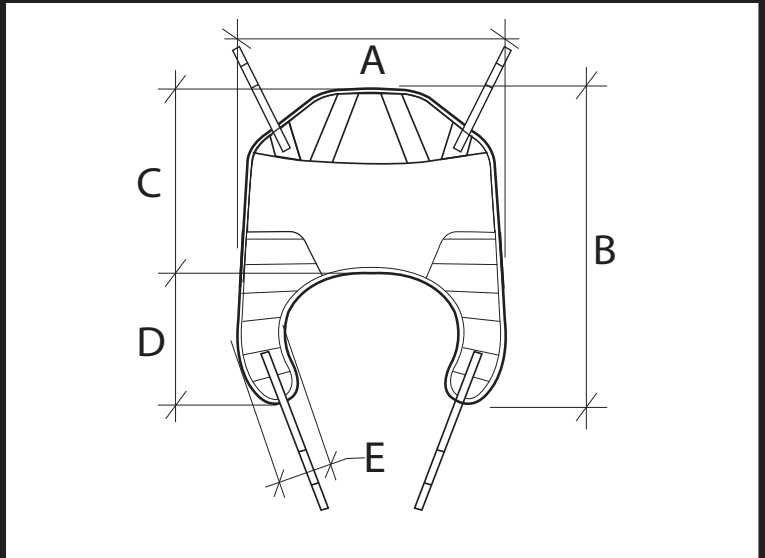

SLING DIMENSIONS (MM) PLEASE TICK BASE MODEL CODE **PLEASE REFER TO SIZE A-E**

SIZE	PAEDIATRIC	SMALL	MEDIUM	LARGE	X-LARGE	SPECIAL
NET	SPECIAL	SPECIAL	SPECIAL	SPECIAL	SPECIAL	Enter in boxes below change (+/-) from standard.
POLYESTER	SL1067	SL1068	SL1069	SL1070	SPECIAL	
POLYESTER PADDED	N/A	N/A	N/A	N/A	N/A	
STANDARD SIZE A=	820	970	1160	1300	25% Increase Over Large	
STANDARD SIZE B=	1350	1425	1530	1760		
STANDARD SIZE C=	845	915	1070	1140		
STANDARD SIZE D=	515	525	530	625		
STANDARD SIZE E=	155	155	155	210		

FOR JOERNS HEALTHCARE CUSTOMER SERVICE USE

TO BE FILLED OUT IN FULL AND FAXED TO CUSTOMER FOR APPROVAL/ORDER No.
JOERNS CONTACT
LEAD TIME Days/Weeks/Months
PRICE QUOTED

PRODUCT OPTIONS PLEASE TICK TO RIGHT

FLEECE LINING TOP VELCRO IN **BODY BELT REQUIRED**
 BOTTOM VELCRO IN IF YES PLEASE STATE DIMS IN BOXES BELOW
 FULL VELCRO IN **DISTANCE TO BELT TOP (C)** mm
HEAD SUPPORT **BELT LENGTH** mm

CUSTOMER TO PHONE OR FAX JOERNS HEALTHCARE CUSTOMER SERVICE TO CONFIRM ACCEPTANCE OF ORDER

CUSTOMER PO No.
ORDERED BY
DATE D D M M Y Y Y Y
SALES ORDER No.
COMMENTS:

PLEASE TICK TO RIGHT AND FILL IN SPECIAL REQUIREMENTS

SHOULDER STRAP	OVERALL LENGTH	440mm	SPECIAL*	mm
HIP STRAP	OVERALL LENGTH	N/A	SPECIAL*	mm
LEG STRAP	OVERALL LENGTH	430mm	SPECIAL*	mm

*** STRAPS WILL BE ADJUSTED FROM THE BASE. ADJUSTMENT LOOPS WILL REMAIN AT SAME DISTANCE FROM STRAP ENDS.**